

Machining Simulation Quick Start For Mill

More video tutorials on <http://www.greatsim.com/>

1. Getting Started:

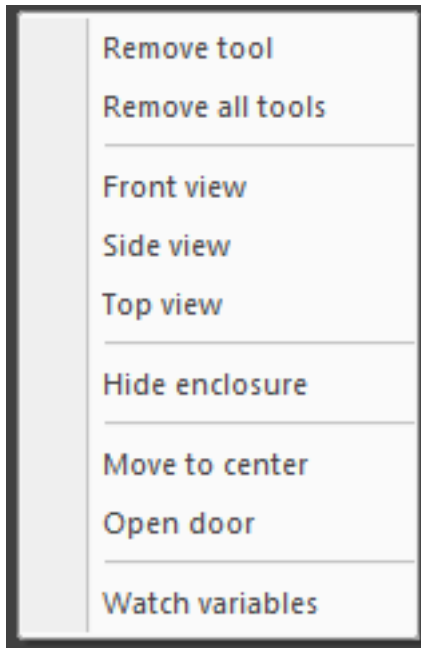

Right Mouse Button Menu:

- Front view: Change view
- Side view: Change view
- Top view: Change view
- Hide/Show enclosure: Hide/show machine enclosure, select "Hide enclosure " or "Show enclosure".
- Move to center: Move to the center of workpiece immediately.
- Open/Close door: To open/close door, release Emergency button and power on, then select "Open door" or "Close door"
- Watch variables: To observe the values of all MACRO variables with the watch window on which local, common and system variables are displayed. The watch window can display several variables after a MACRO program executed.

Transform machine model:

- To rotate machine model, click left mouse button and drag it.
- To zoom in and out machine model, roll mouse wheel to zoom.
- To pan machine model, press mouse wheel and drag with it to pan.

Tips for transforms:

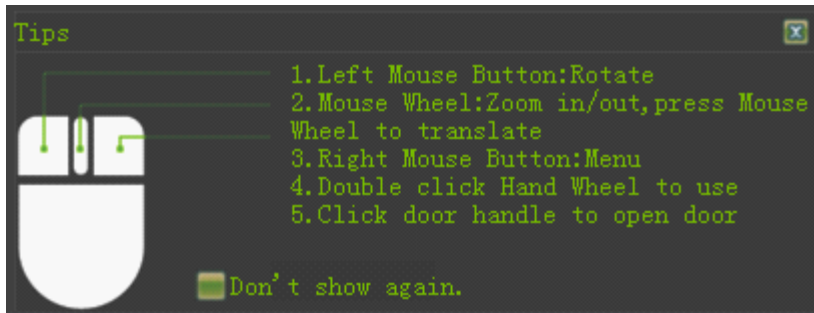

Main menu

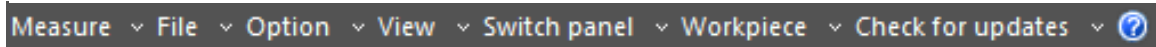

- Measure:
 - ✓ Measure dimension of a workpiece
 - ✓ Estimate CNC machining time for a CNC program.
- File:
 - ✓ Import: Import a CNC program under which EDIT mode is available and a CNC file is opened or created.
 - ✓ Save workpiece: Save machined workpiece.
 - ✓ Read workpiece: Read saved workpiece.
- Options
 - ✓ Displaying programming trace: When on, show programming trace during auto run. When off, hide programming trace.
 - ✓ Display enclosure: When on, show enclosure, when off, hide enclosure.
 - ✓ Sound effect: When on, enable sound, when off, disable sound.
 - ✓ Shadow effect: When on, enable shadow effect, when off, disable shadow effect. If some obsolete display adapters cause several types of problems, such as running slowly, the option better be disabled.

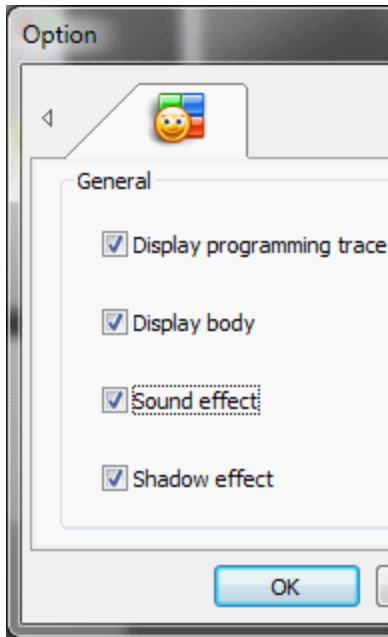

- View
 - ✓ View panels: When CNC panel is closed, use the menu to reopen CNC panel.
 - ✓ Show in dual monitors: Separately show panels and 3D model in dual monitors.
- Switch panel
 - ✓ Switch CNC system to one another.
- Workpiece
 - ✓ Workpiece type: There are two options for box and cylinder.
 - ✓ Quality: Improve the smoothness of workpiece you can see on the screen:
 - Performance: Jaggies
 - Balance: Less jaggies
 - Quality: Smooth, you will experience a decrease in performance with the high value. It is recommended to select a value based on how your display adapter can perform.

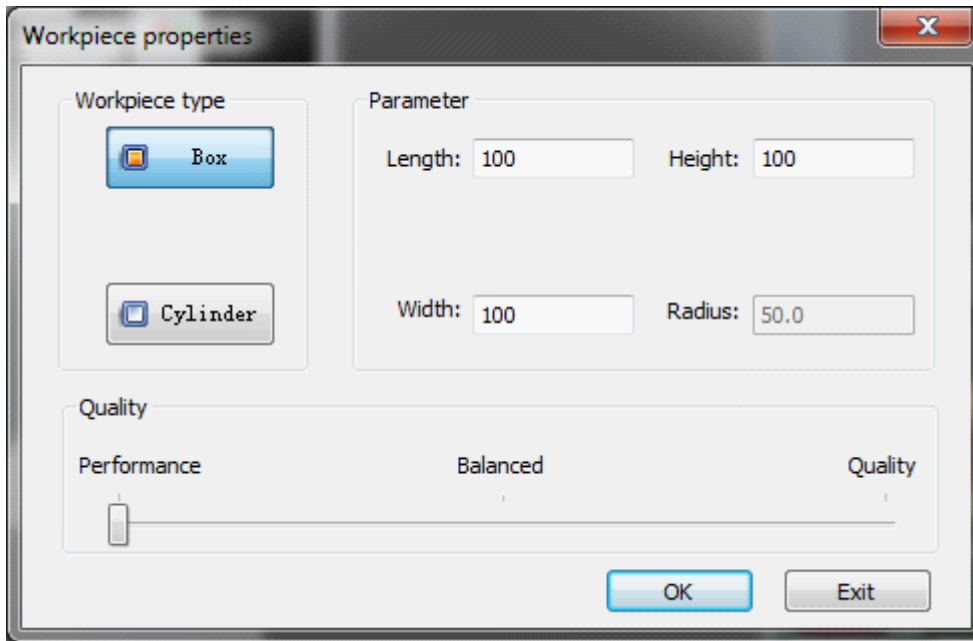

- Check for updates
- ✓ Check if a newer version.

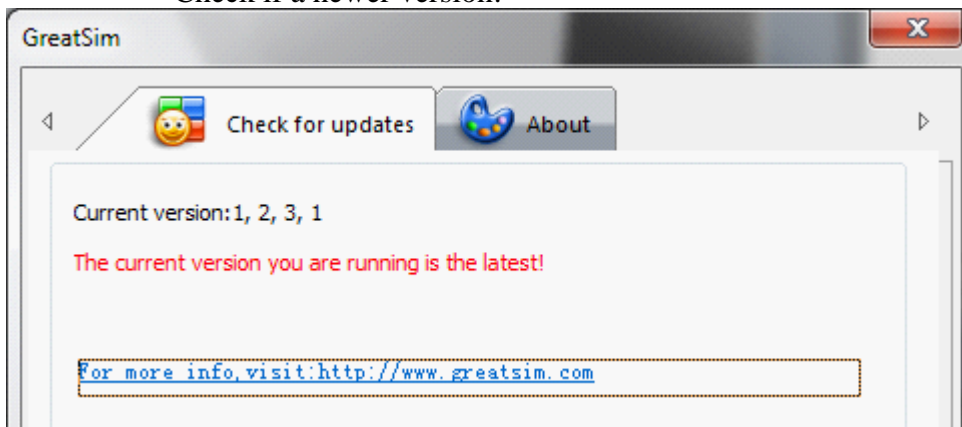

- Help 
- Open the Quick Start document.

2. Tool Library

New a tool

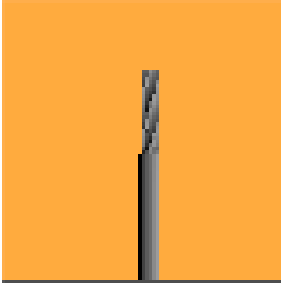

Mouse click the icon to pop up the tool library dialog. The tool list on the left displays all tools available, the turret list on the right displays the tools mounted. Choose the parameters below for shank and the insert to edit

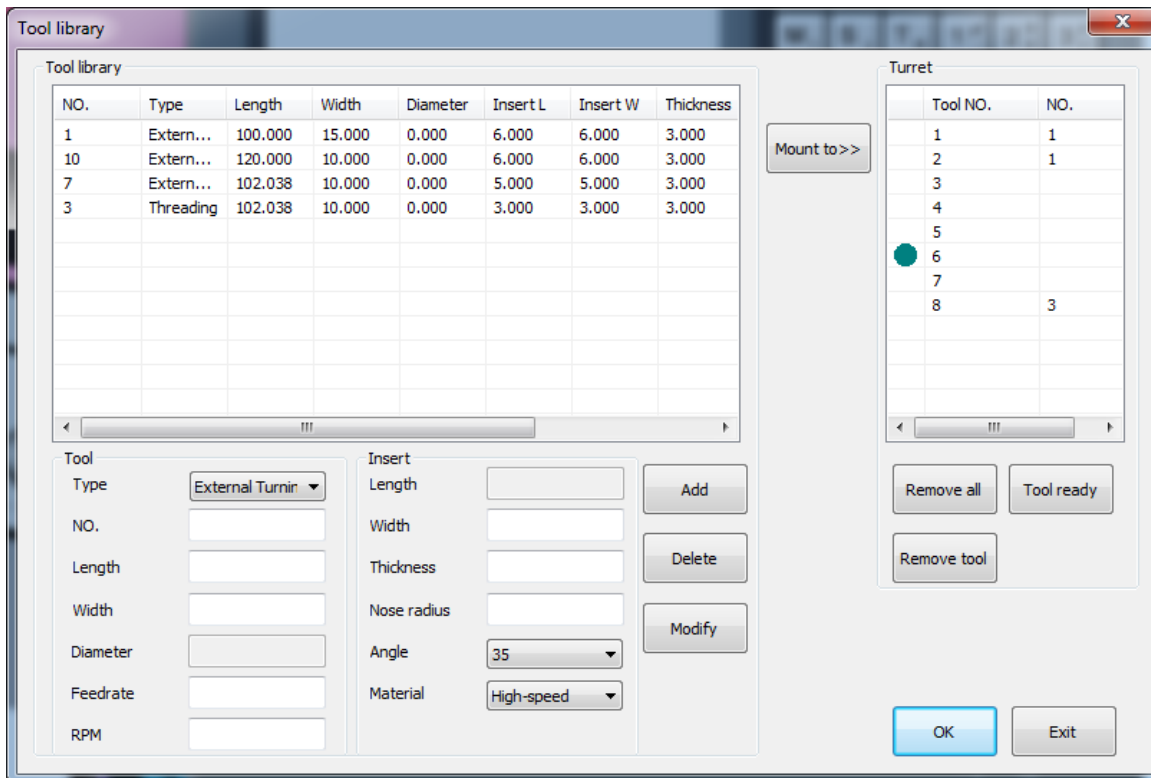

Add a tool:

Input the parameters for shank and insert, press “Add” button.

Tool		Insert		
Type	External Turnin	Length	6.000	Add
NO.	11	Width	6.000	
Length	100.000	Thickness	3.000	
Width	15.000	Nose radius	0.000	Delete
Diameter	0.000	Angle	90	
Feedrate	0.000	Material	High-speed	Modify

Modify a tool

Select a tool from the tool list, its parameters are displayed below for modification, then edit the parameters, press “Modify” button to finish the modification.

Delete a tool:

Select a tool from the tool list, press “Delete” button to delete a tool from the library.

Mount a tool:

Tool library								Turret	
NO.	Type	Length	Width	Diameter	Insert L	Insert W	Thickness	Tool NO.	NO.
1	Extern...	100.000	15.000	0.000	6.000	6.000	3.000	1	1
10	Extern...	120.000	10.000	0.000	6.000	6.000	3.000	2	1
7	Exterr...				5.000	5.000	3.000	3	
3	Threac...				3.000	3.000	3.000	4	
								5	
								6	
								7	

Mount to >>>

Right-click an item of a tool from the tool list, the menu popping up as above picture, select a tool station to mount or press “Mount to” button to do so, the tool mounted is displayed in the turret list. The green circle indicates which tool has been indexed for cutting.

3. CNC Panel

● Buttons

FANUC 0iM Control panel



Emergency button

POWER ON



Power on

POWER OFF



Power off

CYCLE START



Cycle start

CYCLE STOP



Cycle stop



Auto

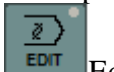

Edit



MDI



INC



Handle



REF



Jog



Coolant



Main spindle CW, Stop, CCW



RAPID



X1
INC



X10
INC



X100
INC



X1000
INC

Rate for INC mode: 0.001, 0.01, 0.1, 1.0



Main spindle override



Feed rate override



Program protect

● Edit program

Press  Edit button and then  PROG button on system panel , select "DIR" , as following :

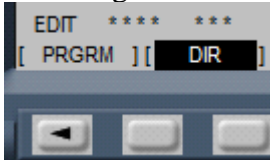

- ✓ Open a CNC program: Enter a CNC program name that exists in the system, such as "O0001", press "Arrow Down" button on system panel

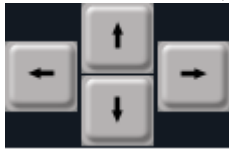

to open it.

- ✓ Create a CNC program: Enter a CNC program name that doesn't exist in the system, such as "O0001", press "Insert"  button. Program protect



must be unlocked before creating a new CNC program.

- ✓ Edit a CNC program:

- ◆ Use the three buttons  to edit a program: Alter,

Insert, Delete. Edit is not available until program protect  is unlocked.

- ✓ Delete a CNC program: Enter a CNC program name, press "Delete" button.
- ✓ Import a CNC program from your disk:

Switch to EDIT mode in the Simulation, and then either create or open a CNC program.

New a Notepad text file.

Enter or paste CNC program into the text file.

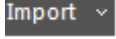

Select "Save as" and select "Save as type:" as "All files".

Enter a file name, such as "XXXX.cnc" or "XXXX.nc".

Use Import  menu in the Simulation to select the file, click "Open".

The file is imported.

● Auto run

Open , create or import a CNC program , press  , then press  Cycle start .

Press  to enable Single Block. When on, CNC program will be executed in a single block, when off, the function is disabled.

● Offset input

- ✓ WORK: Workpiece Coordinate System (G54-G59)

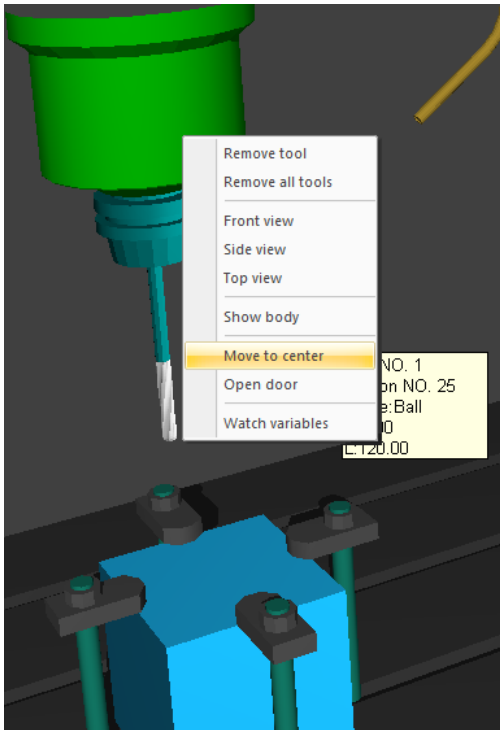

Select “Move to center”, the tool tip is located to the center of end face of workpiece.

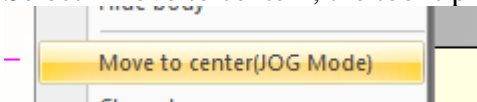



Press “OFFSET SETTING” button on FANUC panel, press “WORK” soft key,

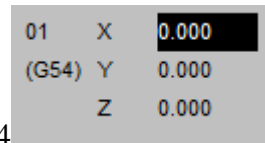
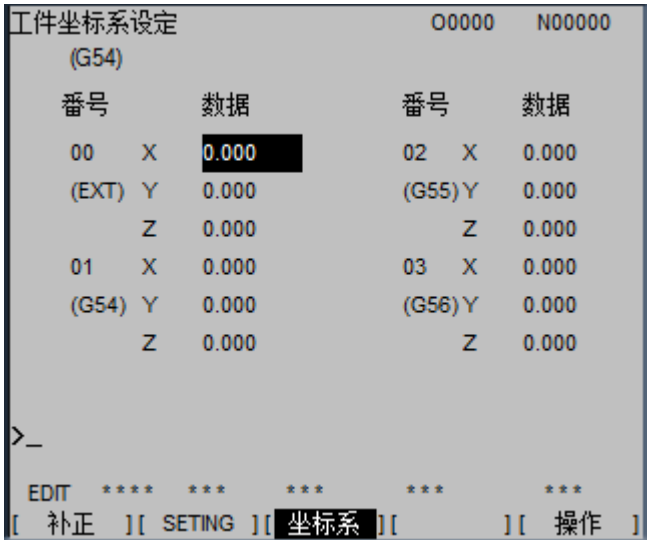

Use the arrow buttons to select G54,





input X0, press “Measure” soft key to finish the input for X-axis, the operations for Y and Z axis are the same as for X axis.

● MDI

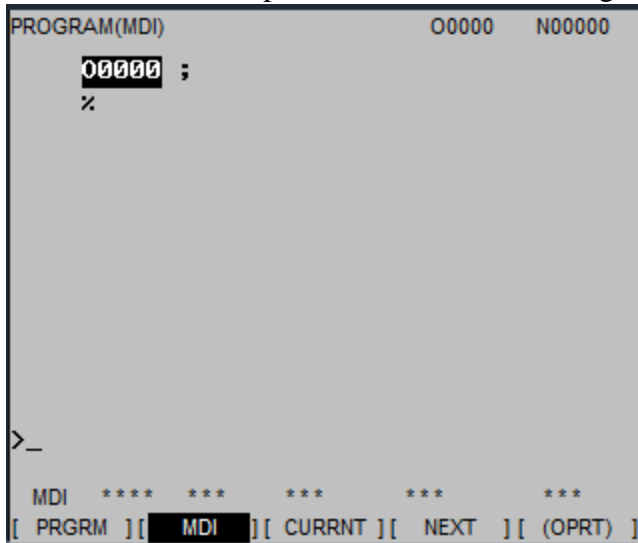

Press  button , press  button , an image shown as following:



Select "MDI", enter a block, such as "G54X0Y0Z0", press  to execute the block you enter.

● Use Hand Wheel



✓ Switch to WHEEL or HND  mode on the operator panel, Double Click on Hand Wheel. To close Hand Wheel, Double Click on it again.

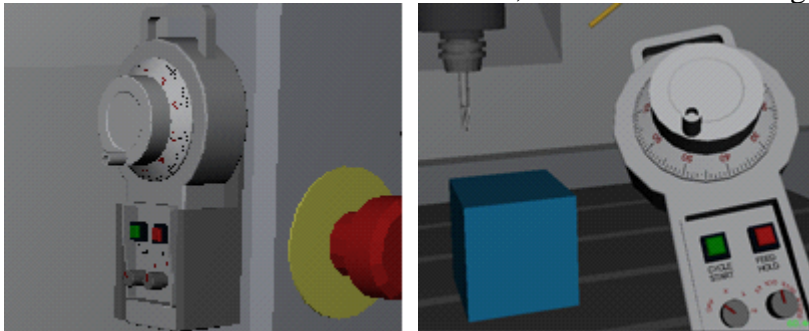

- ✓ Select an axis from X-Z axis by rotating the Axis Selection switch.
- ✓ Select a rate from X1-X1000 by rotating the Rate Selection switch.

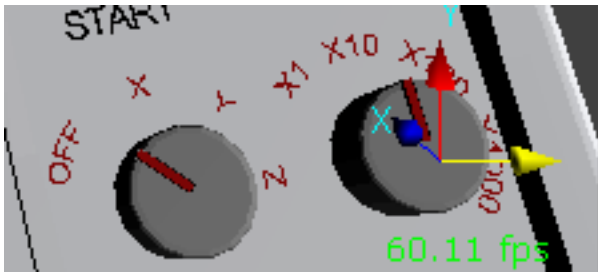

Note

If there is a problem with displaying 3D model, please upgrade your display card driver and make sure the hardware accelerations are enabled before running the application.